

PROUDLY SUPPORTED BY



TRAFFIC MANAGEMENT
ASSOCIATION OF AUSTRALIA



itsaustralia
Intelligent Transport Systems



NATIONAL PRECAST
CONCRETE ASSOCIATION AUSTRALIA

HIGHWAY ENGINEERING AUSTRALIA

V52.3



TRANSPORT
INFRASTRUCTURE
ITS TECHNOLOGY
SINCE 1968

PRINT POST APPROVED - 100001888



**TOWARDS ZERO
BRIDGE FATALITIES**



DOLRE LOW STRESS PARAPET SYSTEM

AN INNOVATIVE SOLUTION TO A COMMON PROBLEM

Although widely considered as a critical step in ensuring that our road bridge assets are able to meet the needs of our ever-changing vehicle mix, the adoption of Australian Bridge Standard AS5100:2017 - which references the MASH-2016 standards - has rendered a lot of bridge traffic barrier assets obsolete.

Together with a significant increase in vehicle numbers, the past three decades have also seen significant changes in vehicle design - including materials used, size, shape and mass. And while it may seem the task of ensuring bridges comply with the new Standard is simply matter of 'swapping out' an existing barrier for a newer model with greater structural capacity to cater for larger and/or heavier vehicles, in reality, it is a far more complex challenge than it first appears.



TOWARDS ZERO BRIDGE FATALITIES

THE CHALLENGE

One of the main challenges is that most existing bridge decks have not been designed with the structural capacity to meet the needs of higher capacity, traditionally designed bridge traffic barriers.

The reason: transfer of impact energy.

Put simply, the energy of an impact into a traditional bridge traffic barrier affects more than just the traffic barrier itself. It flows through the barrier to the bridge deck and then the greater structure.

In many cases, the increase in load from the traffic barrier is too great for the bridge deck capacity, and the bridge deck will be damaged. Thus, the greater majority of existing bridges are unable to be fitted with higher capacity, traditionally designed barriers without first being fitted with additional reinforcement such as carbon fibre – an expensive solution in terms of both time and cost. In some instances, increasing the capacity of the traditional bridge traffic barrier would necessitate a complete replacement of the bridge deck.



INNOVATION TOWARDS ZERO

THE SOLUTION

The innovative solution to this common problem has come in the form of a bridge traffic barrier system developed by Belgian bridge engineer, David De Saedeleer, a director of Belgian manufacturer Desami.

Working with world-renowned FEA specialists Global Design Solutions (GDTech), Desami developed a ground-breaking design that restricts the energy from the vehicle impact to a fraction of the capacity of the bridge deck, resulting in a low load in the bridge deck.

Known as the DOLRE Low Stress Parapet System, this world-leading bridge traffic barrier system has been fully crash tested to European Standards and simulated to US MASH TL4 requirements, and has been Approved by ASBAP for use throughout Australia.

Ideal for bridge refurbishment projects, the DOLRE Low Stress Parapet System offers a cost-effective and easy to install method of upgrading existing bridges to meet the current Standard without the need for significant and expensive deck strengthening or deck replacement works. DOLRE also offers the added advantage of being easy to dismantle and remove in times of flood, thereby helping to significantly reduce the risk of damage to valuable bridge assets.



DEVELOPMENT OF THE DOLRE BRIDGE TRAFFIC BARRIER IN EUROPE

Unlike its neighbours Germany, France and the Netherlands, Belgium was a relative late starter in the construction of motorways. Indeed, construction of Belgium's first motorway (Brussels to Antwerp) only started in 1971. This motorway construction was soon followed by a number of other projects, with expansion of the country's motorway network continuing at a rapid pace thereafter. This provided Belgians and their industrial powerhouse neighbours with routes across Belgium to markets, ports and the industrial hubs of Europe.

A significant number of bridges were built to service both motorways and byways in the 1970s and 80s. All of these bridges were required to be constructed with a standard parapet design known as the Mailloux parapet. The Mailloux design used weak posts that transferred low stresses to the bridge deck during an impact.

Following Belgium's decision to adopt the European standard for common testing and certification procedures for road restraint systems in 1989, the Mailloux parapet was doomed. The new European Standard EN1317.2 was first published 1998 and superseded some 12 years later by EN1317-2010.

Belgium's bridges had been struggling with the rapid changes in traffic since the



ABOVE: Use of the old style, non-tested, Mailloux parapet design ceased in Belgium following the introduction of the European Standard EN1317.2

1970s. Higher traffic densities, higher speeds, and larger vehicles (particularly trucks) were all factors of concern. Belgium's engineers were struggling with the new requirements of EN1317. It was no longer the case that a single traffic barrier was mandated, it was now about designing barriers for containment - while at the same time preserving the bridge deck.

Belgium adopted the EN1317 H4b containment level for parapets on motorway bridges, and EN1317 H2 containment level for lesser bridges on truck routes. These new barrier designs created stress levels that old bridge decks could not accommodate, and costs to rehabilitate the bridge decks escalated.

In 2014, the Belgian government offered several large R&D grants, one of which was for research into roadside safety.

A partnership between local Belgian companies Desami and Global Design Technologies (aka "GDTEch") won one of the grants.

An iterative process utilising Finite Element analysis was utilised together with the relevant Eurocodes to design, refine and optimise a solution for the vehicle barriers on bridge decks to EN1317-2010 containment levels, without creating large stresses in the bridge decks.

With the resulting DOLRE barrier, the stresses transferred to the bridge deck during an impact are less than one third of the stresses created by a conventional barrier. Given the cost savings resulting from use of the DOLRE barrier for bridge refurbishment works, it is little wonder that Desami already has some 83 contracts either completed or in progress for bridge works in France and Belgium.

BELOW: Engineering and numerical modelling was confirmed using full-scale crash tests, thereby allowing the product to be CE certified to the EN1317 Standard.

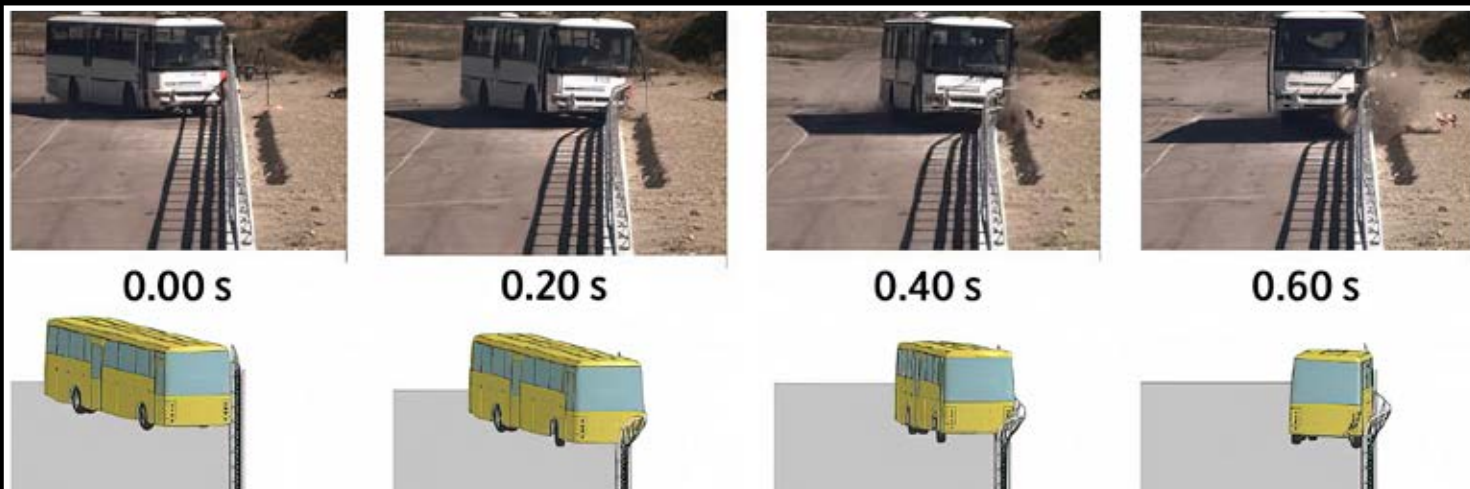

TOWARDS COMPLIANCE OF THE DOLRE BRIDGE TRAFFIC BARRIER IN AUSTRALIA

The key to DOLRE's performance lies within the post, which is unique in both shape and purpose. The post is designed using computer algorithms to maximise the performance of the overall traffic barrier system. Not only is the post architecturally and aesthetically pleasing, it is also an efficient shape to support the rails. Most importantly, the post is extremely efficient in transferring a maximum transverse load, which is restricted to just 43kN per post for the DOLRE Regular performance parapet.

Another unique feature of the DOLRE Regular performance traffic barrier is the transition to MASH TL4 Thrie-Beam. This design feature provides an engineered continuity of MASH TL4 protection on either side of the DOLRE Regular traffic barrier.

Engineers recognise that conducting full-scale crash testing on a transition to every combination of product in the market would be a severe financial burden which ultimately would restrict the progress of safety in the industry. To counter this, it is becoming the norm to utilise virtual testing in conjunction with the dynamics observed in the full-scale crash tests of the products to assess the performance of transitions between products.

The DOLRE Regular transition has been assessed against both European EN1317 H2 impacts and US MASH TL4 impacts for transitions. In all cases, the transition was deemed to have met the assessment criteria for these impacts.

With the increasing reliance on virtual testing, there is also increasing importance on ensuring that the virtual tests are validated. Both Europe and America have standards for assessing the validity of a virtual test. The reference documents for validation are TR16303-2012 and NCHRP 179-2010 for Europe and the US respectively. DOLRE, being a European product, naturally had its virtual testing being validated against TR16303-2012, but as Australia uses the American MASH standard, these virtual tests also needed to be analysed using the NCHRP 179-2010 methodology. It may be noted that DOLRE is the first traffic barrier introduced to Australia to satisfy all of these criteria.

The virtual testing of the DOLRE products has been heavily scrutinised and accepted by ASBAP (Austroads Safety Barrier Assessment Panel). In all, a comprehensive suite of some 22 crash test reports or simulated test reports have been produced for the DOLRE Regular performance traffic barrier. These performance reports, together with other documents were submitted to ASBAP for assessment, with ASBAP subsequently recommending the DOLRE MASH TL4 traffic barrier for use to the six SRAs and the two territory road authorities.

As DOLRE is mainly focused on bridge applications, the next step was an independent structural assessment of the DOLRE traffic barrier against the requirements of the AS5100:2017 bridge standard. The entire package of reports and documents on the DOLRE low stress parapet has been analysed by independent specialist bridge structural engineers. Again, DOLRE has been assessed as complying with the requirements of AS5100:2017.

DOLRE is an innovative product in a niche market for bridge refurbishment. In Australia, DOLRE complies with Australian standards AS/NZS3845:2015 and AS5100:2017, has been ASBAP approved, and has been independently approved by two consulting bridge engineers.

The DOLRE Low Stress Parapet System now available throughout Australia and New Zealand exclusively from road safety systems and engineering specialists LB Australia Pty Ltd.

For further information, contact LB Australia Pty Ltd, Ph: 1300 522 878 or Email: roadsafety@lbaustralia.com.au



Transition Test #1
for 2270kg Ute

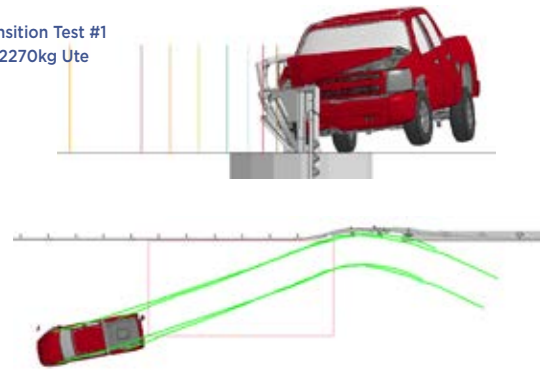

Transition Test #2
for 2270kg Ute

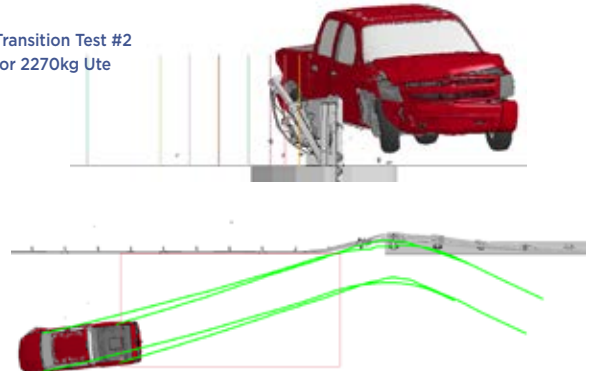

Transition Test #3
for 2270kg Ute

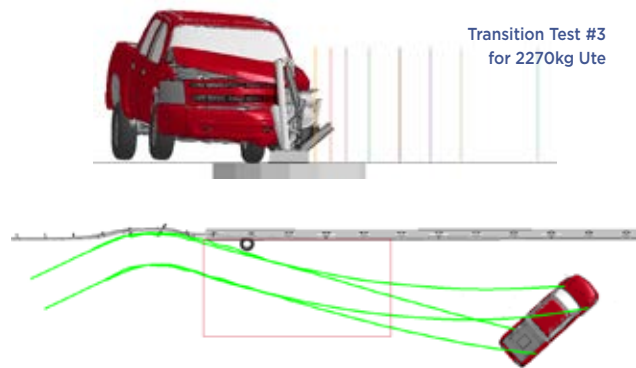

Transition Test #1
for 900kg Sedan

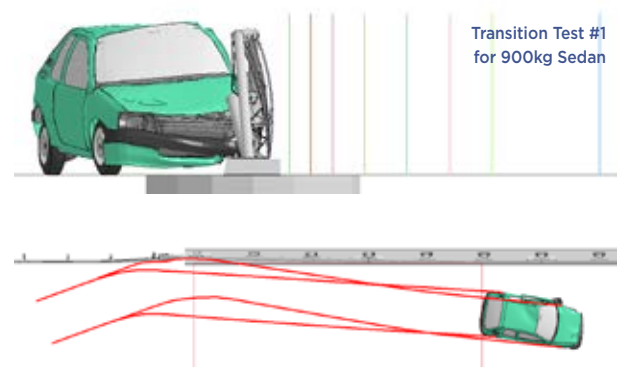

Transition Test #1
for 13,000kg Bus

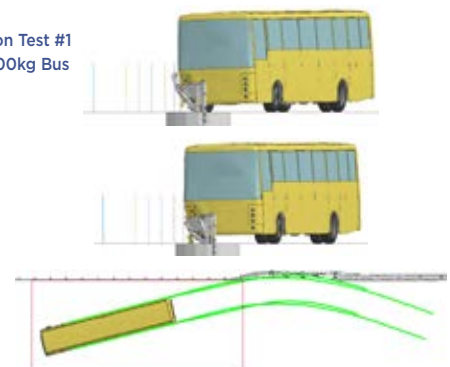

**Ideal for
Bridge Refurbishment
Projects.**

**ASBAP Approved
for use in Australia**



**TOWARDS ZERO
BRIDGE FATALITIES**

- Fully crash tested to European Standards and simulated to US MASH TL4 requirements
- Unique design imparting low stress to bridge deck - protecting water proofing membranes and coatings on the deck
- Easy to install
- Easy to dismantle in times of flood
- Cost-effective bridge rehabilitation solution

**INNOVATION
TOWARDS ZERO**



www.lbaustralia.com.au Ph 1300 522 878